

the Revolutionary War

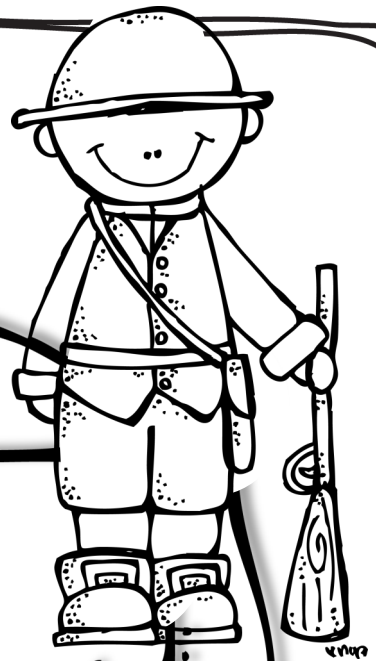

Student Activity Packet

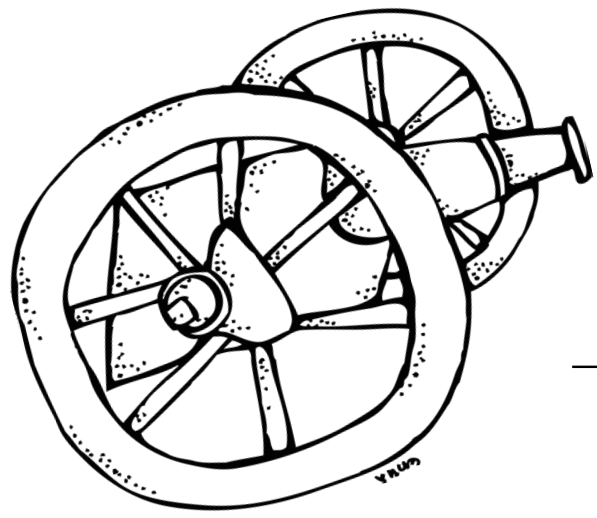

Name:

Lesson 1

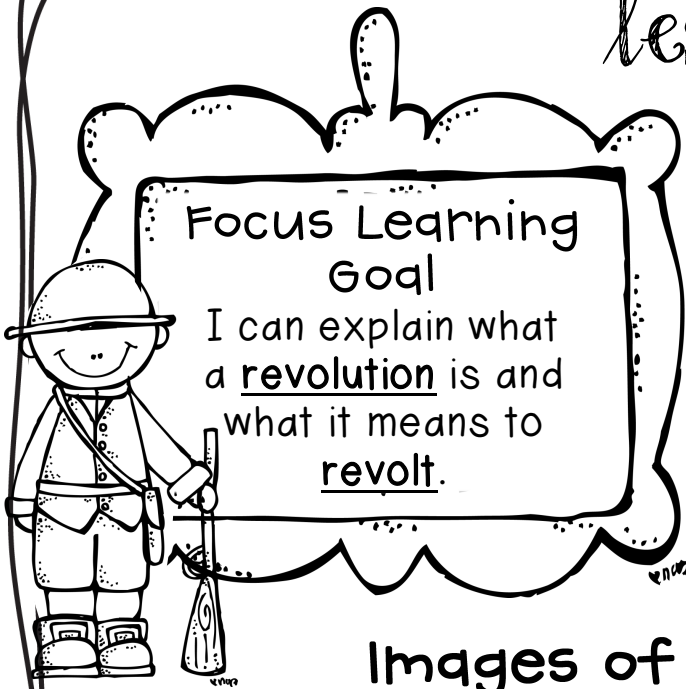

What is a Revolution?

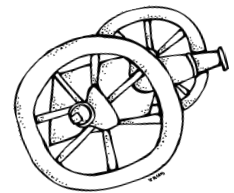

Images of the Revolution

Look through each picture card and record your thoughts and ideas about each card below.

1

What event do you think is taking place in this image?

2

Does this image show a positive or negative event? Explain.

3

Why might these men be playing the drums and flute?

Lesson 1 - continued

4

What do you think the man riding the horse is telling the people who are looking out the window?

5

What do you think the people on the ship are throwing into the water?

6

What words come to mind when you see this image?

7

What do you think these men are discussing?

8

Notice the crumpled paper on the floor. What do you think these men are writing?

Lesson 1 - continued

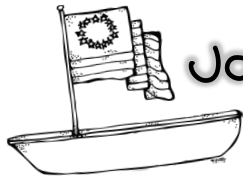

Journal Question:

What is one liberty, or freedom, that you value today?

Place an "X" in one of the boxes below.

Focus Learning Goal	I've Got It!	Still working on It!	I Need Help!
I can explain what a <u>revolution</u> is and what it means to <u>revolt</u> .			

I gave myself this rating because: _____

Lesson 2

Focus Learning Goal

I can explain what the French and Indian War was.

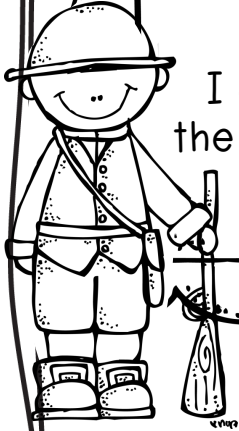

The French and Indian War

A War to Start a War



- Bodies of Water
- English Colonies
- Disputed Land

The French and Indian War was a conflict that took place between 1754-1763. Fighting began when the French (with their Native American allies) and Britain both wanted the land found west of the colonies. This land was full of natural resources. The two countries disputed, or disagreed, over who the land should belong to.

When the French finally lost the war, Britain gained the new land. However, the war was very expensive to fund. Britain now had to raise money to pay for the war. The colonies, already owned by Britain, were expected to help pay for the war, even though they did not cause the war.

Lesson 2 - continued

Britain felt that it was ok to ask the colonies to help pay for the war since the land that Britain won during the war would help benefit the colonists. The colonists disagreed and the tension between Britain and the colonies grew.

Use the information you have just learned about the French and Indian War to answer the questions below.

What was the French and Indian War fought over?

What is an ally? Use a dictionary if needed.

Who won the war and what did they win?

Why were the colonists unhappy with Britain after the war was over?

Lesson 2 - continued

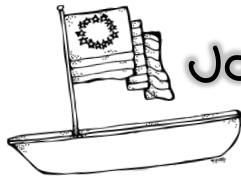

Journal Question:

Do think it was fair for Britain to expect the colonists to help pay for the French and Indian War? Why or Why not?

Place an "X" in one of the boxes below.

Focus Learning Goal	I've Got It!	Still working on It!	I Need Help!
I can explain what the French and Indian War was.			

I gave myself this rating because: _____

Lesson 3

Focus Learning Goal

I can explain what
"No Taxation
Without Representation"
means.



No Taxation Without Representation

What is a tax?

What does
"No Taxation without Representation!"
mean?

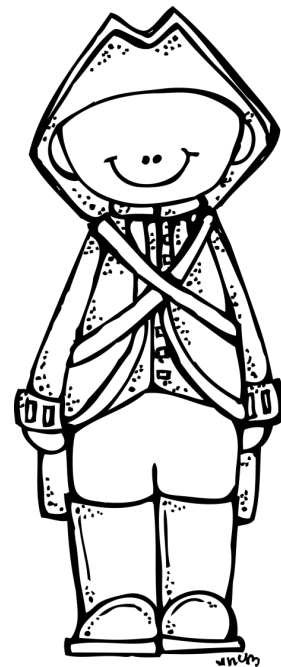

Lesson 3 - continued

King George and the colonists disagreed about the taxes that the colonists had to pay. Fill in the speech bubbles below of something King George might have said about the taxes and what a colonist might have said about the taxes.



King George

A large, rounded speech bubble pointing towards King George. Inside the bubble are five horizontal lines for writing a response.A large, rounded speech bubble pointing towards the colonist. Inside the bubble are five horizontal lines for writing a response.

Colonist

Lesson 3 - continued

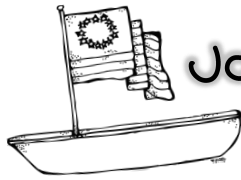

Journal Question:

If you were a colonist living during the Revolutionary War time, do you think you would be apart of the "Sons of Liberty?" Explain your thinking.

Place an "X" in one of the boxes below.

Focus Learning Goal	I've Got It!	Still working on It!	I Need Help!
I can explain what "No Taxation Without Representation" means.			

I gave myself this rating because: _____

Lesson 4

Focus Learning Goal

I can explain 4 different taxes that the colonists were forced to pay and the impact it had on them.



Taxes, Taxes, and More Taxes!

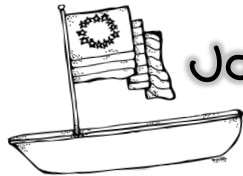

Journal Question:

Of all of the acts that were passed by the British, which act do you think was the biggest violation of the colonists' rights? Why?

Place an "X" in one of the boxes below.

Focus Learning Goal	I've Got It!	Still working on It!	I Need Help!
I can explain 4 different taxes that the colonists were forced to pay and the impact it had on them.			

I gave myself this rating because: _____

Lesson 5

Focus Learning Goal

I can explain what the Boston Massacre was.

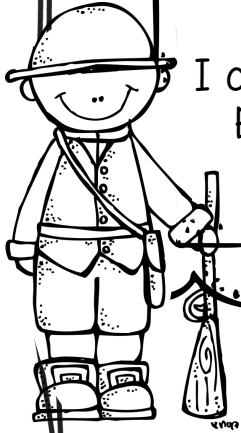

The Boston Massacre

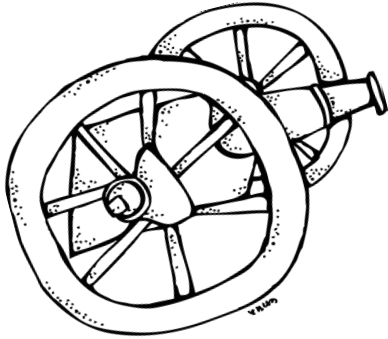
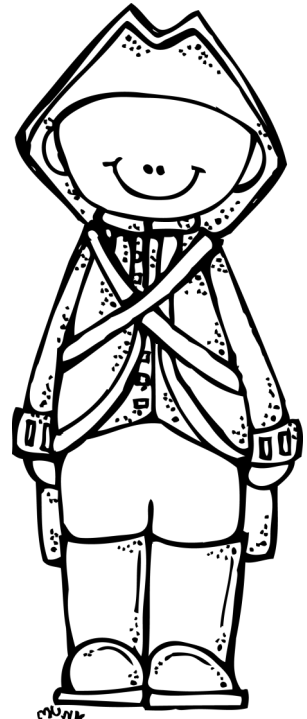

The Boston Massacre

It got out of hand

It all started when

It resulted in

Lesson 5 - continued

Two Perspectives of the Boston Massacre:



I think this painting is from the perspective of a:

because:

I think this painting is from the perspective of a:

because:



Lesson 5 - continued

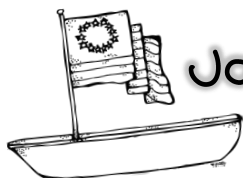

Journal Question:

Tension is growing between the colonists and the British.
What do you think will happen next?

Place an "X" in one of the boxes below.

Focus Learning Goal	I've Got It!	Still working on It!	I Need Help!
I can explain what the Boston Massacre was.			

I gave myself this rating because: _____

Lesson 6

Focus Learning Goal

I can explain what the Tea Act was and how this act caused the Boston Tea Party.

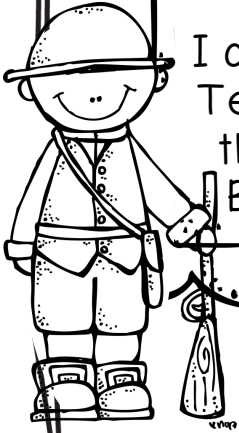

The Tea Act and The Boston Tea Party



The Tea Act was: _____

The colonists were angry that they were only allowed to buy tea from the East India Tea Company. The tea act caused colonists to become even more angry with the British. Just like they had done with the other taxes, the colonists decided to protest this act. One evening in 1773, some colonists, disguised as Native Americans, snuck onto a British ship that was loaded with tea and dumped boxes and boxes of tea into the Boston Harbor.

Watch the video clip to learn more about this event that became known as The Boston Tea Party.

Lesson 6 - continued

Results of The Boston Tea Party:

King George was very angry when he heard about the Boston Tea Party. He decided to punish the colonists by _____

Use the graphic organizer below to prepare for your news article on the Boston Tea Party.

who?

what?

why?

how?

where?

when?

Lesson 6 - continued

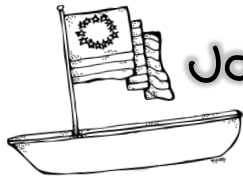

Journal Question:

List as many words as you can that describe the Boston Tea Party.

Place an "X" in one of the boxes below.

Focus Learning Goal	I've Got It!	Still working on It!	I Need Help!
I can explain what the Tea Act was and how this act caused the Boston Tea Party.			

I gave myself this rating because: _____

Lesson 7

Focus Learning
Goal
I can explain what the
Intolerable Acts were
and what the First
Continental Congress
was.

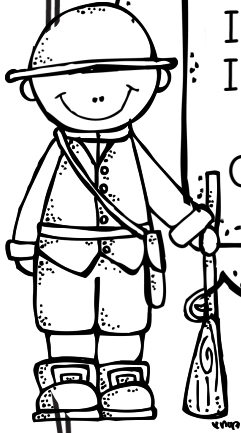

The Intolerable Acts and The First Continental Congress

Intolerable

What kinds of things do you think are "intolerable" in your own life? Jot them in the box below.

Lesson 7 - continued

Tea Act



Boston Tea Party



Intolerable Acts

The Intolerable Acts were: _____



The First Continental Congress



The First Continental Congress was: _____

Lesson 7 - continued

You are attending the First Continental Congress. You and your fellow colonists are angry with the king because of the unfair Intolerable Acts that he has forced on the colonies. Make a list of all the complaints that you have toward the King and Parliament. Then use your list to create a letter that you will send to the King. Be sure to tell the King what the colonists are prepared to do if he does NOT change his ways.

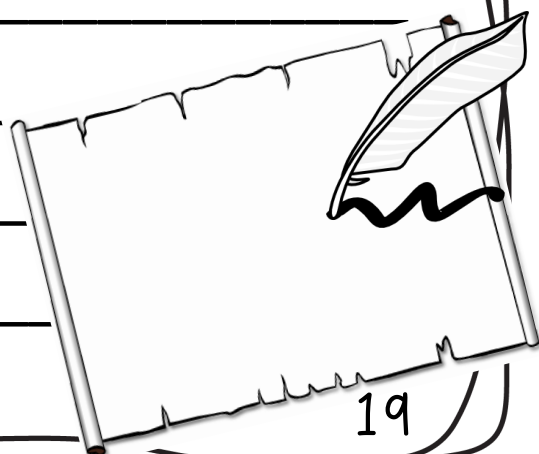

Lesson 7 - continued

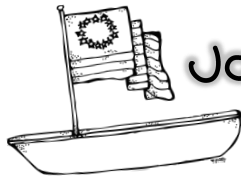

Journal Question:

You have learned that the men at the First Continental Congress had to meet in secret because they could get into serious trouble if the British found out. How do you think these men felt as they met secretly for the first time?

Place an "X" in one of the boxes below.

Focus Learning Goal	I've Got It!	Still working on It!	I Need Help!
I can explain what the Intolerable Acts were and what the First Continental Congress was.			

I gave myself this rating because: _____

Lesson 8

Focus Learning Goal

I can explain the difference between a patriot and a loyalist.



Patriots vs. Loyalists

A Patriot is: _____

A Loyalist is: _____



Journal Question:

If you lived during the Revolutionary War time, would you have been a patriot or a loyalist? Why?

Lesson 8 - continued

Place an "X" in one of the boxes below.

Focus Learning Goal	I've Got It!	Still working on It!	I Need Help!
I can explain the difference between a patriot and a loyalist.			

I gave myself this rating because: _____

Lesson 9

Focus Learning Goal

I can explain the causes of the war and describe the first two battles of the revolution.

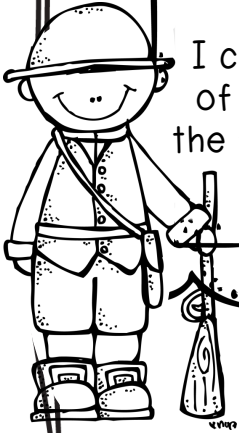

The Revolution Begins!

Cause

The British won the French and Indian War.



Effect

Cause

Britain had a lot of debt after the French and Indian War.



Effect

Lesson 9 - continued

Cause

Effect

5 men were killed
in Boston after a
riot broke out.

Cause

Effect

Colonists snuck
onto an English ship
and dumped barrels
of English tea into
the Boston Harbor.

Cause

Effect

Angered by the
Boston Tea Party,
the King passed the
"Intolerable Acts"
to punish the
colonists.

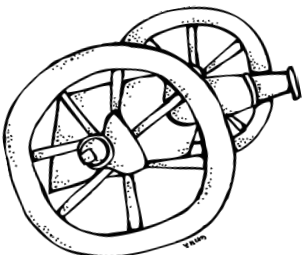

war was coming...

Lesson 9 - continued

Who fought in the war?

Minuteman

A "minuteman" was a _____ who was prepared to begin _____ at any minute. These men knew that at any moment _____ could begin.

Redcoat:

A "redcoat" was the _____ given to a British _____. This was because the British army wore _____.

In the space below, illustrate the "*Shot Heard Around the World.*" use pictures and speech bubbles to show the action of the battle.

Lesson 9 - continued

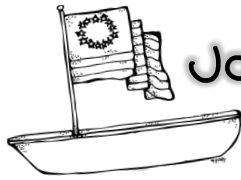

Journal Question:

When you were reenacting the “Shot Heard Around the World,” did it feel natural to want to fire back after the first “shot” was released? How do you think colonists felt when they heard the first shot in the real battle?

Place an “X” in one of the boxes below.

Focus Learning Goal	I've Got It!	Still working on It!	I Need Help!
I can explain the causes of the war and describe the first two battles of the revolution.			

I gave myself this rating because: _____

The next few pages are to be used in the
SAP if you choose "Option 1" Only
(See Unit Plan notes for lessons 10-12 for
details)

If you choose "Option 2," please skip to
page 40 of this file.

Lesson 10

Focus Learning Goal

I can explore some of the major events of the war and place the event on a timeline.



Major Events of the War

{part 1}

Revolutionary War Learning Folders

As you explore the major events of the war, record important information about each event below.

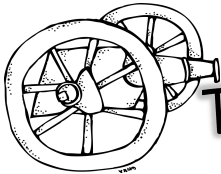

The Second Continental Congress

Who?

What?

Where?

When?

Why?

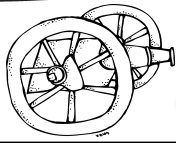

Lesson 10 - continued

Capture of Fort Ticonderoga

Who?	What?
Where?	
When?	Why?

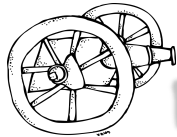

Battle of Bunker Hill

Who?	What?
Where?	
When?	Why?

Lesson 10 - continued

Place an "X" in one of the boxes below.

Focus Learning Goal	I've Got It!	Still working on It!	I Need Help!
I can explore some of the major events of the war and place the event on a timeline.			

I gave myself this rating because: _____

Lesson 11

Focus Learning Goal

I can explain what the "Declaration of Independence" is.

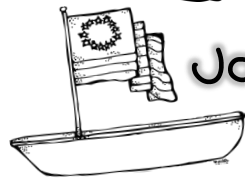

The Declaration of Independence

Journal Question:

What word or words would you use to describe the men who wrote their signatures on the Declaration of Independence? Why did you choose those words?

Place an "X" in one of the boxes below.

Focus Learning Goal	I've Got It!	Still working on It!	I Need Help!
I can explain what the "Declaration of Independence" is.			

I gave myself this rating because: _____

Lesson 12

Focus Learning Goal

I can explore some of the major events of the war and place the event on a timeline.



Major Events of the War

{Part 2}

Revolutionary War Learning Folders

As you explore the major events of the war, record important information about each event below.

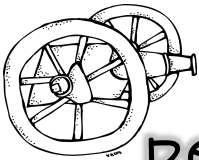

George Washington Crosses the Delaware and the Battle of Trenton

Who?

What?

Where?

When?

Why?

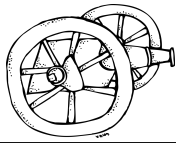

Lesson 12 - continued

Battles of Saratoga

Who?	What?
Where?	
When?	Why?

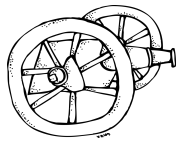

Battle of Yorktown

Who?	What?
Where?	
When?	Why?

lesson 12 - continued

Place an "X" in one of the boxes below.

Focus Learning Goal	I've Got It!	Still working on It!	I Need Help!
I can explore some of the major events of the war and place the event on a timeline.			

I gave myself this rating because: _____

Lesson 13

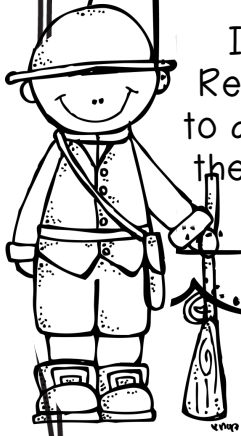

Focus Learning Goal

I can explain how the Revolutionary War came to an end and who became the first President of the United States.

The End of the Revolution and a New Presidency

The Treaty of Paris

A treaty is: _____

What is the difference between a king and a president?

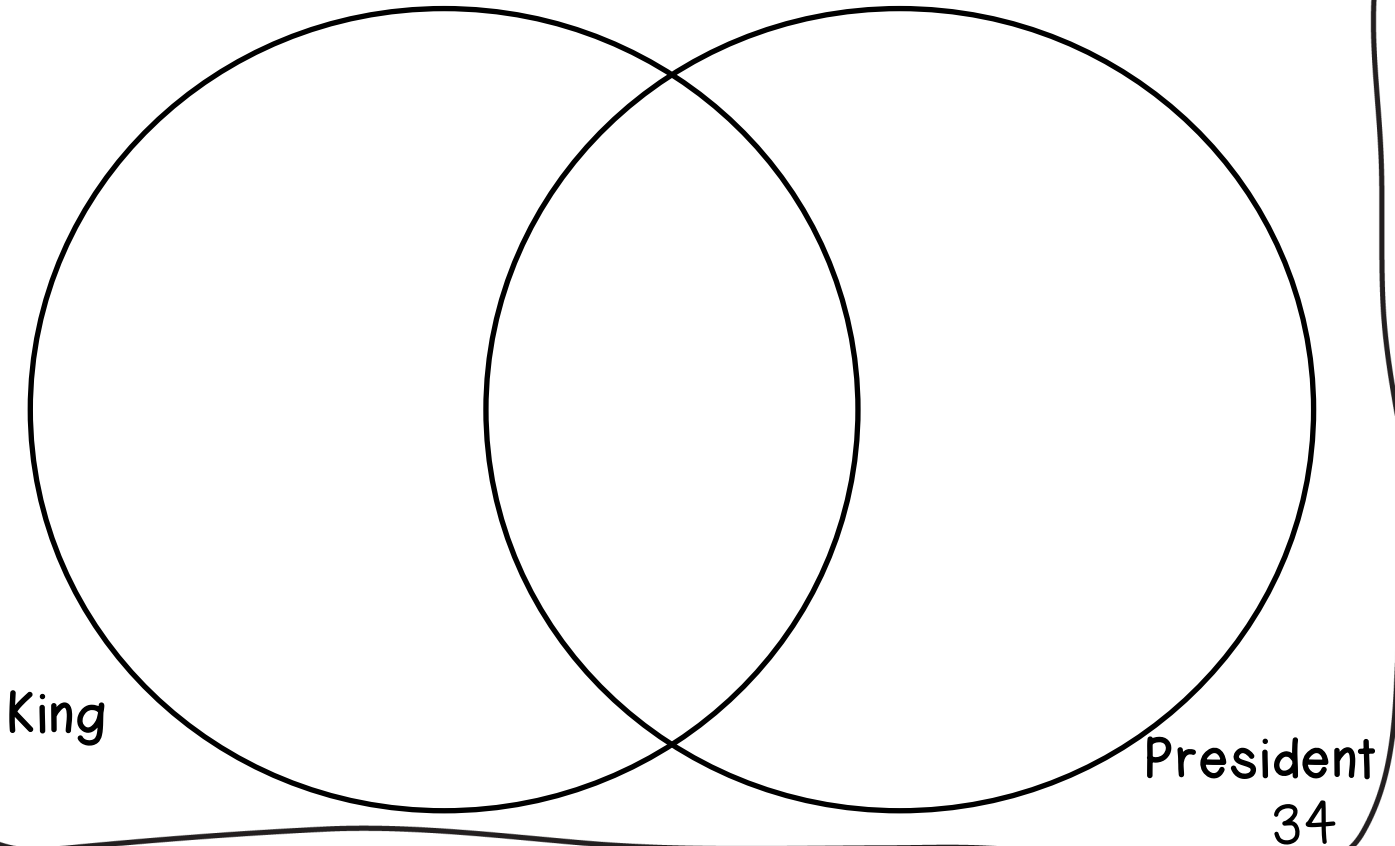

Lesson 13 - continued



Journal Question:

Why do you think George Washington was hesitant about becoming the first President of the United States?

Place an "X" in one of the boxes below.

Focus Learning Goal	I've Got It!	Still working on It!	I Need Help!
I can explain how the Revolutionary War came to an end and who became the first President of the United States.			

I gave myself this rating because: _____

the road to freedom...

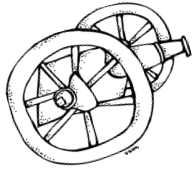

{A Timeline of the American Revolution}



{ 1492-1763 }

Colonial America

{ _____ }

{ _____ }

{ _____ }

{ _____ }

{ _____ }

{ _____ }

{ _____ }

{ _____ }

{ _____ }

{ _____ }

{ _____ }

{ _____ }

{ _____ }

{timeline - continued}

{ _____ } _____

{ _____ } _____

{ _____ } _____

{ _____ } _____

{ _____ } _____

{ _____ } _____

{ _____ } _____



The next few pages are to be used in the
SAP if you choose “Option 2”
(See Unit Plan notes for lessons 10-12 for
details)

Create a separate packet for “Major
Events” Sheets as needed. You will need
one sheet for each event that you choose
for your students to learn about.

Lesson 10

Focus Learning Goal

I can explore some of the major events of the war and place the event on a timeline.



Major Events of the War

{part 1}

Place an "X" in one of the boxes below.

Focus Learning Goal	I've Got It!	Still working on it!	I Need Help!
I can explore some of the major events of the war and place the event on a timeline.			

I gave myself this rating because: _____

Lesson 11

Focus Learning Goal

I can explain what the "Declaration of Independence" is.

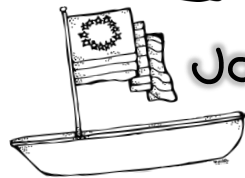

The Declaration of Independence

Journal Question:

What word or words would you use to describe the men who wrote their signatures on the Declaration of Independence? Why did you choose those words?

Place an "X" in one of the boxes below.

Focus Learning Goal	I've Got It!	Still working on It!	I Need Help!
I can explain what the "Declaration of Independence" is.			

I gave myself this rating because: _____

Lesson 12

Focus Learning Goal

I can explore some of the major events of the war and place the event on a timeline.



Major Events of the War

{Part 2}

Place an "X" in one of the boxes below.

Focus Learning Goal	I've Got It!	Still working on It!	I Need Help!
I can explore some of the major events of the war and place the event on a timeline.			

I gave myself this rating because: _____

Lesson 13

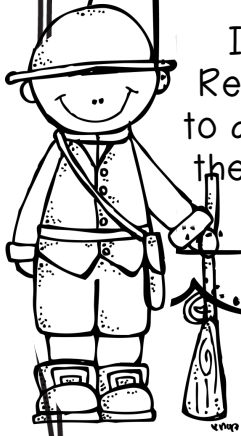

Focus Learning Goal

I can explain how the Revolutionary War came to an end and who became the first President of the United States.

The End of the Revolution and a New Presidency

The Treaty of Paris

A treaty is: _____

What is the difference between a king and a president?

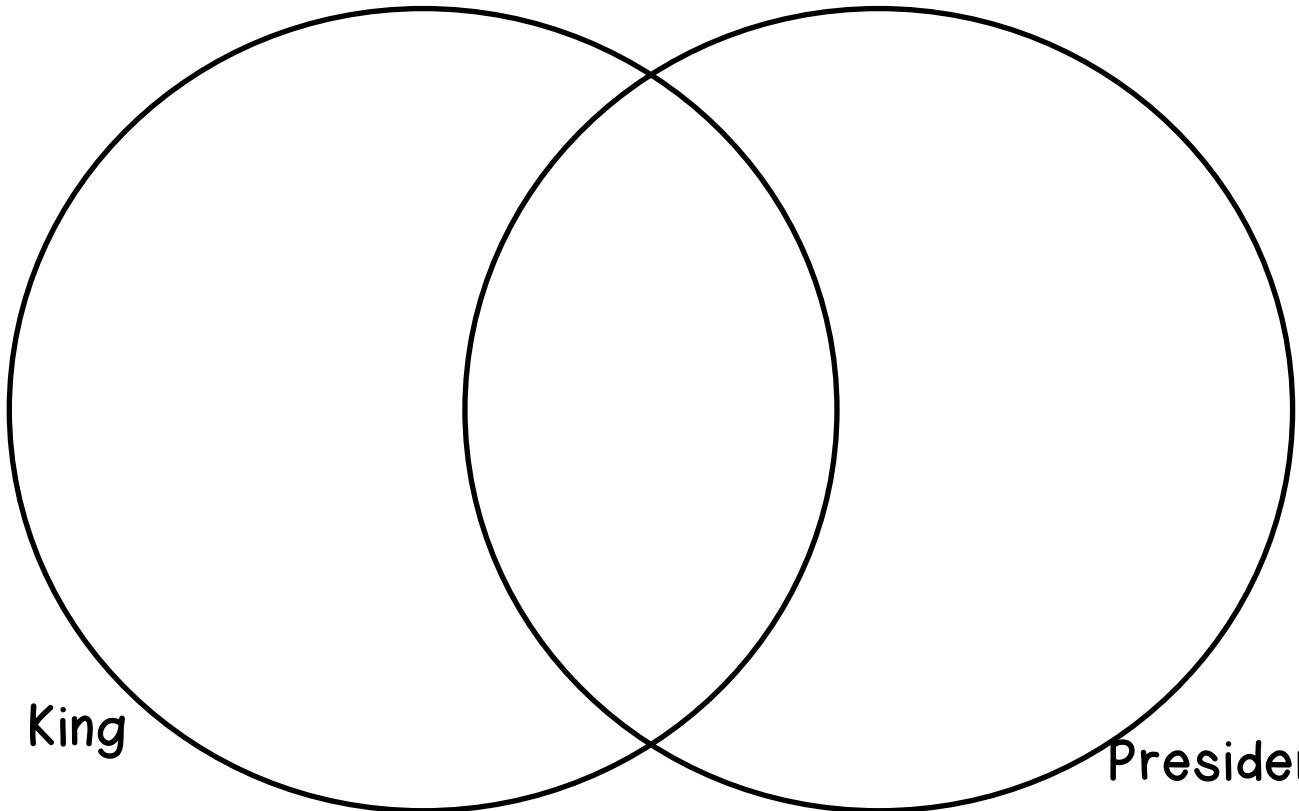

King

President

Lesson 13 - continued

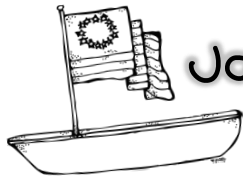

Journal Question:

Why do you think George Washington was hesitant about becoming the first President of the United States?

Place an "X" in one of the boxes below.

Focus Learning Goal	I've Got It!	Still working on It!	I Need Help!
I can explain how the Revolutionary War came to an end and who became the first President of the United States.			

I gave myself this rating because: _____

the road to freedom...

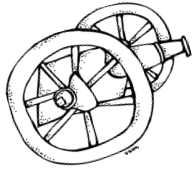

{A Timeline of the American Revolution}



{ 1492-1763 }

Colonial America

{ _____ }

{ _____ }

{ _____ }

{ _____ }

{ _____ }

{ _____ }

{ _____ }

{ _____ }

{ _____ }

{ _____ }

{ _____ }

{ _____ }

{ _____ }

{timeline - continued}

{ _____ } _____

{ _____ } _____

{ _____ } _____

{ _____ } _____

{ _____ } _____

{ _____ } _____

{ _____ } _____

